

Fluid control valve(2/2way)

Coil and accessories



Hookup

Coil's type		Hookup	Connector's type
116 Series	CDA116 (Terminal)	AC	PL2925
	CLA116 (Grommet)	DC	
170 Series	CDA170 (Terminal)	AC	PL3030
		DC	
	CLA170 (Grommet)	AC	-
		DC	

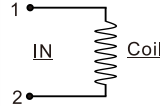

How to use connector

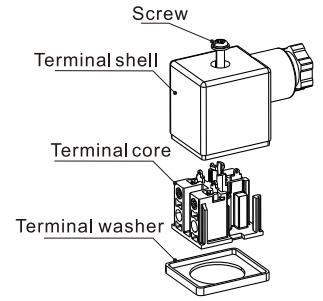

Specification

Model/Item	Power type	Voltage (V)	Frequency (Hz)	Voltage range	Electrical entry	Power Consumption (VA/W)		Insulation	Temp.rise(°C)	
						For NC	For NO		NC	NO
116 Series	AC	220	50	±15%	DIN Terminal	10.0VA	15.0VA	Class B	35	50
			60			8.0VA	11.0VA		30	40
		110	50			10.0VA	15.0VA		35	50
			60			8.0VA	11.0VA		30	40
	24	50	10.0VA	15.0VA	35	50				
		60	8.0VA	11.0VA	30	40				
	DC	24	-	±10%	Grommet	6.5W			30	30
		12	-			12.0W			40	40
170 Series	AC	220	50	±15%	DIN Terminal	25.0VA	35.0VA	Class H	60	65
			60			22.0VA	30.0VA		55	60
		110	50			25.0VA	35.0VA		60	65
			60			22.0VA	30.0VA		55	60
	24	50	25.0VA	35.0VA	60	65				
		60	22.0VA	30.0VA	55	60				
	DC	24	-	±10%	Grommet	12.0W			40	40
		12	-			12.0W			40	40

How to select coil

Valve type\Coil type		116 Series		170 Series	
		Class B	Class H	Class B	Class H
2W□030\2KW□030	2S□030\2KS□030	●	×	×	×
2L□030	2KL□030	×	●	×	×
2W□050\2KW□050	2S□050\2KS□050	×	×	●	×
2L□050	2KL□050	×	×	×	●
2W150~250\2KW150~250	2S150~250\2KS150~250	●	×	×	×
2L150~250	2KL150~250	×	●	×	×
2S320~500	2KS320~500	×	×	●	×
2L320~500	2KL320~500	×	×	×	●

How to select accessories

Valve type\Accessories type			F-2S030LB	F-2S050LB	F-2S150LB	F-2S200LB	F-2S250LB
2W□030\2KW□030	2S□030\2KS□030	2L□030\2KL□030	●	×	×	×	×
2W□050\2KW□050	2S□050\2KS□050	2L□050\2KL□050	×	●	×	×	×
2W150\2KW150	2S150\2KS150	2L150\2KL150	×	×	●	×	×
2W200\2KW200	2S200\2KS200	2L200\2KL200	×	×	×	●	×
2W250\2KW250	2S250\2KS250	2L250\2KL250	×	×	×	×	●
2S320~500\2KS320~500	2L320~500\2KL320~500		×	×	×	×	×

Ordering code of coil

CD A116 A □

① ② ③ ④

① Coil type	② Coil's bore	③ Voltage	④ Temperature resistance class of coil
CD: Terminal CL: Grommet	A116: Coil Specification(Bore sizeΦ11.6mm) A170: Coil Specification(Bore sizeΦ17.0mm)	A: AC220V B: DC24V C: AC110V E: AC24V F: DC12V	Blank: B Class H: H Class